

MITERED BORDERS

Supplies needed:

Straight Pins
Seam gauge or small ruler with $\frac{1}{4}$ " markings
Iron and pressing surface

Instructions:

1. Pin a border strip to one side of the quilt top with the ends of the border strip extending past **both** edges of the quilt top by at least the width of the border strip plus 1". *{Example: if the border strip is 6" wide, then the ends of the strip should extend beyond both edges of the quilt top by 7" (6" + 1" = 7").}*

* **Formula:** $1" + \text{width of border} + \text{block width} + \text{width of border} + 1" = \text{minimum length to cut the border strip.}$

2. Sew the border strip to the quilt top right sides together starting and stopping the seam $\frac{1}{4}$ " from each edge of the quilt top. Press seams toward the border.

Sew the border strips to the quilt top starting and stopping $\frac{1}{4}$ " from each end.

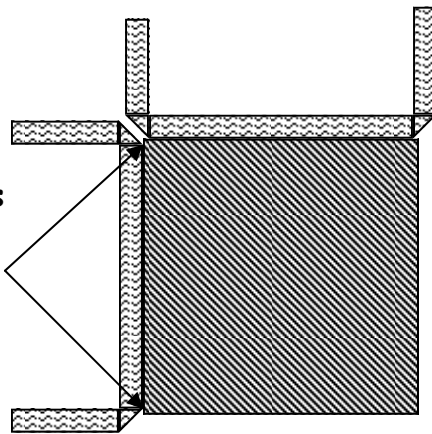

Press the seams toward the borders.

3. Once the seams are pressed out toward the borders, overlap the ends of two adjoining borders making sure to lay them flat.

Overlap the ends of two adjoining borders, laying them flat.

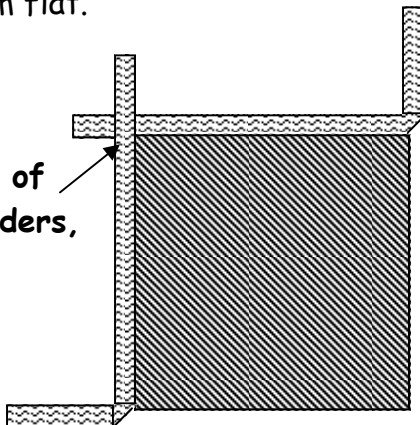

MITERED BORDERS

4. Fold one border strip down in a 45° angle and line it up evenly with the adjoining border. It should be folded from the point at which the stitching stopped $\frac{1}{4}$ " from the end of the quilt top edge. Press the fold to form a crease.

5. Pin the two borders together beyond the fold to hold them securely in place for stitching.

Press the fold to form a crease. Pin the side border to the top border beyond the crease to keep them evenly aligned for sewing.

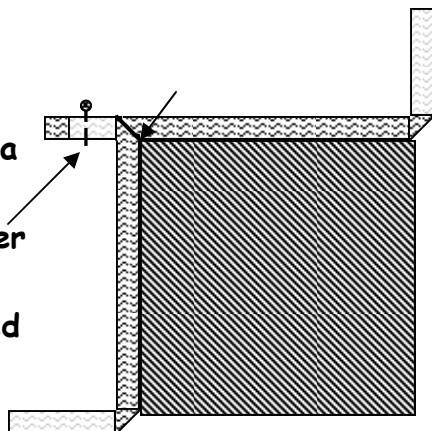

Fold the side border down with a 45° angle and align it evenly with the top border. The fold should start at the point where the stitching stopped $\frac{1}{4}$ " from the end.

6. Fold the quilt top diagonally with the right sides of the fabric together so that the edges of the two borders are lined up evenly together. Sew on the crease starting at the point where the seams of the two borders stopped $\frac{1}{4}$ " from the edge of the quilt top and continue sewing out to the edge of the borders.

Start sewing here.

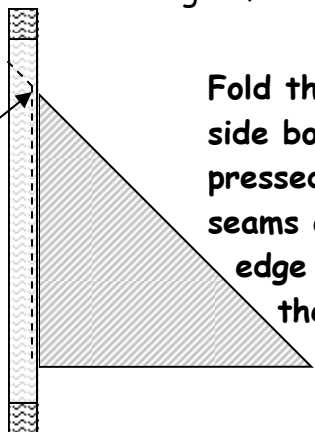

Fold the quilt top diagonally so that the top and side borders are lined up evenly. Sew on the pressed crease starting at the point where the seams of the two borders stopped $\frac{1}{4}$ " from the edge of the quilt top and continue sewing out to the edge of the two borders.

7. Open the quilt top and lay it out to check that the mitered corner is lying flat and is completely connected with no "hole" in the seam line.

Open the quilt top and lay it flat to check that the mitered corner lays flat and connects completely where the two borders and the quilt top come together.

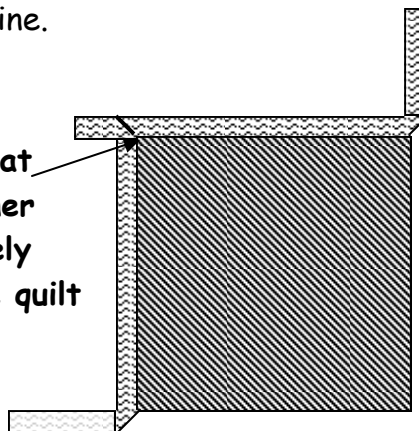

MITERED BORDERS

8. If there is no "hole" in the seam line, fold the quilt top once more and trim the seam allowance to $\frac{1}{4}$ ". If there is a "hole" in the seam, stitch it shut and then trim the seam allowance. Repeat steps # 1 through # 8 for the remaining three corners.

Trim to $\frac{1}{4}$ "
seam allowance.

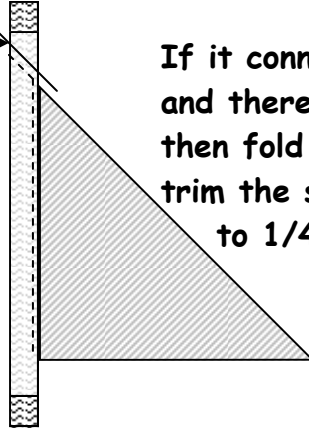

If it connects properly
and there is no "hole",
then fold it again and
trim the seam allowance
to $\frac{1}{4}$ ".